



US00D621752S

(12) **United States Design Patent**
Angelo et al.

(10) **Patent No.:** **US D621,752 S**

(45) **Date of Patent:** **** *Aug. 17, 2010**

(54) **TRUCK BUMPER COMPONENT**

(74) *Attorney, Agent, or Firm*—Christensen O'Connor Johnson Kindness PLLC

(75) Inventors: **Gerald J. Angelo**, Bellevue, WA (US);
Wallace A. Peltola, Sammamish, WA (US)

(57) **CLAIM**

The ornamental design for a truck bumper component, as shown and described.

(73) Assignee: **PACCAR Inc**, Bellevue, WA (US)

(**) Term: **14 Years**

(21) Appl. No.: **29/346,948**

DESCRIPTION

(22) Filed: **Nov. 9, 2009**

(51) **LOC (9) Cl.** **12-16**

(52) **U.S. Cl.** **D12/169**

(58) **Field of Classification Search** D12/169,
D12/196, 171, 163, 216, 90–92, 86; 293/102,
293/113, 115, 117, 120; 296/180.1, 180.2
See application file for complete search history.

FIG. 1 is a front perspective view of a truck bumper component showing a first embodiment of our new design, the second embodiment of the truck bumper component for use on the opposite side of a truck is a minor image that is not presently shown;

FIG. 2 is a front elevational view of the truck bumper component of FIG. 1;

FIG. 3 is a rear elevational view of the truck bumper component of FIG. 1;

FIG. 4 is a top plan view of the truck bumper component of FIG. 1;

FIG. 5 is a bottom plan view of the truck bumper component of FIG. 1;

FIG. 6 is a left side elevational view of the truck bumper component of FIG. 1; and,

FIG. 7 is a right side elevational view of the truck bumper component of FIG. 1.

The broken line showing of a wheel, truck fender, portion of truck hood, and portion of a truck cab is for the purpose of illustrating environmental structure and forms not part of the claimed design.

The truck bumper component shown in FIGS. 1–7 illustrates a first embodiment of our novel design suitable for use on the driver's side of a truck. Our novel design also includes a second embodiment suitable for use on the passenger's side of the truck, which is mirror symmetrical to FIGS. 1–7, and, therefore, not separately illustrated.

(56) **References Cited**

U.S. PATENT DOCUMENTS

D291,982 S	9/1987	Simons
D307,254 S	4/1990	Koske
D307,731 S	5/1990	Kerney
D308,032 S	5/1990	Kerney
D311,712 S	10/1990	Marlowe
D312,805 S	12/1990	Marlowe
D313,966 S	1/1991	Marlowe
D316,241 S	4/1991	Ray
D319,807 S	9/1991	Simons
D320,583 S	10/1991	Simons
D343,597 S	1/1994	Meryman
D343,605 S	1/1994	Meryman
D364,371 S	11/1995	Ray

(Continued)

OTHER PUBLICATIONS

"T800," Kenworth Truck Company, Kirkland, Washington, 2003, 32-page brochure.

(Continued)

Primary Examiner—Melody N Brown

1 Claim, 5 Drawing Sheets

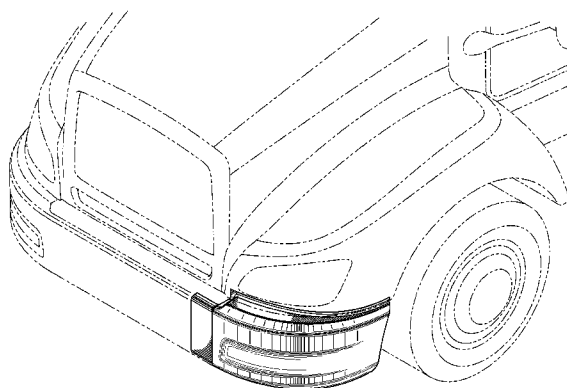

U.S. PATENT DOCUMENTS

D567,725 S * 4/2008 Spearman-Oxx et al. ... D12/169

D366,638 S 1/1996 Tucker
 D381,946 S 8/1997 Delashaw
 D382,841 S 8/1997 Norwood
 D384,019 S 9/1997 Meryman
 D391,212 S 2/1998 Meryman
 D395,860 S 7/1998 Meryman
 D403,636 S 1/1999 Meryman
 D411,140 S 6/1999 Meryman
 D411,494 S 6/1999 Meryman
 D412,689 S 8/1999 Onopa
 D422,251 S 4/2000 Bader
 D423,429 S 4/2000 Hickman
 D423,990 S 5/2000 Meryman
 D425,450 S 5/2000 Barraclough
 D429,669 S 8/2000 Cook
 D437,258 S 2/2001 Meryman
 D442,132 S 5/2001 Weidhase
 D443,853 S * 6/2001 Barraclough et al. D12/196
 D450,277 S 11/2001 Onopa
 D455,381 S 4/2002 Maher
 D458,565 S 6/2002 Maher
 D460,023 S 7/2002 Beigel
 D465,749 S 11/2002 Beigel
 D466,450 S 12/2002 Maher
 D466,847 S 12/2002 Waskow
 D471,494 S 3/2003 Chan
 D475,663 S 6/2003 Chiang
 D475,664 S 6/2003 Chiang
 D476,929 S 7/2003 Dozier
 D477,258 S 7/2003 Hayashi
 D478,027 S 8/2003 Chiang
 D478,028 S 8/2003 Chiang
 D482,302 S 11/2003 Dozier
 D483,707 S 12/2003 Satou
 D488,749 S 4/2004 Ikuma
 D490,749 S 6/2004 Satou
 D491,496 S 6/2004 Metros
 D491,848 S 6/2004 Metros
 D491,851 S 6/2004 Perfetti
 D492,627 S 7/2004 Metros
 D492,628 S 7/2004 Bond
 D492,801 S 7/2004 Metros
 D494,898 S 8/2004 Metros
 D497,577 S 10/2004 Metros
 D497,581 S 10/2004 Conway
 D497,851 S 11/2004 Metros
 D498,716 S 11/2004 Maeda
 D501,809 S 2/2005 Metros
 D504,850 S * 5/2005 Gunter et al. D12/169
 D512,351 S 12/2005 Hattori
 D515,989 S 2/2006 Choi
 D518,424 S 4/2006 Clark
 D519,067 S 4/2006 Steere
 D519,068 S 4/2006 Clark
 D519,069 S * 4/2006 Clark et al. D12/169
 D530,653 S 10/2006 Angelo
 D531,940 S 11/2006 McCuller
 D539,704 S 4/2007 Angelo
 D540,722 S * 4/2007 Angelo et al. D12/169
 D543,914 S 6/2007 Lai
 D545,248 S 6/2007 Angelo
 D545,735 S 7/2007 Angelo
 D561,647 S 2/2008 Simons
 D563,281 S 3/2008 Simons
 D563,840 S 3/2008 Simons
 D564,423 S * 3/2008 Spearman-Oxx et al. ... D12/169
 D565,484 S 4/2008 Johnson

OTHER PUBLICATIONS

"T800," Kenworth Truck Company, Kirkland, Washington, 2005, 28-page brochure.
 "7800B," Kenworth Truck Company, Kirkland, Washington, 1993, 8-page brochure.
 "The Working Class," Peterbilt Motors Company, Newark, California, Sep. 1976, 6 page brochure.
 "The World's Best," Kenworth Truck Company, Kirkland, Washington, 1992, 12-page brochure.
 "Unibilt™ Cab Sleeper System," Peterbilt Motors Company, Denton Texas, Aug. 1994, 6 page brochure.
 "W900," Kenworth Truck Company, Kirkland, Washington, 1996, 7-page brochure.
 "W900," Kenworth Truck Company, Kirkland, Washington, 2002, 32-page brochure.
 "W900," Kenworth Truck Company, Kirkland, Washington, 2005, 28-page brochure.
 "W900L Aero Cab," Kenworth Truck Company, Kirkland, Washington, 1994, 2-page brochure.
 "AeroCab," Kenworth Truck Company, Kirkland, Washington, 1993, 6-page brochure.
 "AeroCab," Kenworth Truck Company, Kirkland, Washington, as early as 1995, 3-page brochure.
 "C500B," Kenworth Truck Company, Kirkland, Washington, as early as 1990, 4-page brochure.
 "Cabovers," Peterbilt Motors Company, Newark, California, as early as 2000, 7 page brochure.
 "Class Pays," Peterbilt Motors Company, Denton, Texas, Sep. 1997, 10-page brochure.
 "Class Pays," Peterbilt Motors Company, Denton, Texas, Nov. 1998, 10 page brochure.
 "Class Pays, Construction Trucks," Peterbilt Motors Company, Denton, Texas, Nov. 2003, 16-page brochure.
 "Class Pays, Ergonomic Dash," Peterbilt Motors Company, Denton, Texas, Mar. 2000, 2 page brochure.
 "Class Pays, Medium Duty," Peterbilt Motors Company, Denton, Texas, Sep. 2000, 12-page brochure.
 "Class Pays, Platinum Interior," Peterbilt Motors Company, Denton, Texas, May 2005, 4 page brochure. Li.
 "Class Pays, Refuse Trucks," Peterbilt Motors Company, Denton, Texas, Sep. 2003, 2 page brochure.
 "Class Pays, Truck Models," Peterbilt Motors Company, Denton, Texas, Mar. 2005, 24-page brochure.
 "Construction Trucks," Canadian Kenworth Truck, Mississauga, Ontario, Canada, Jul. 1990, 16-page brochure.
 "Interiors," Kenworth Truck Company, Kirkland, Washington, 2005, 16-page brochure.
 "K100E," Kenworth Truck Company, Kirkland, Washington, 1984, 8-page brochure.
 "Model 320," Peterbilt Motors Company, Denton, Texas, May 1996, 2 page brochure.
 "Model 330," Peterbilt Motors Company, Denton, Texas, Oct. 1997, 3 page brochure.
 "Model 357," Peterbilt Motors Company, Denton, Texas, May 1994, 3-page brochure.
 "Model 357 Heavy Haul," Peterbilt Motors Company, Denton, Texas, Mar. 2005, 2 page brochure.
 "Model 357, New Sloped Hood," Peterbilt Motors Company, Denton, Texas, May 2002, 2 page brochure.
 "Model 357 Standard Specifications," Peterbilt Motors Company, Newark, California, Sep. 1986, 6 page brochure.
 "Model 357-115," Peterbilt Motors Company, Denton, Texas, Mar. 2005, 2 page brochure.
 "Model 362," Peterbilt Motors Company, Newark, California, 1985, 8-page brochure.
 "Model 375 Standard Specifications," Peterbilt Motors Company, Newark, California, Sep. 1986, 6 page brochure.
 "Model 377A/E," Peterbilt Motors Company, Denton, Texas, Jan. 1995, 6-page brochure.

US D621,752 S

Page 3

"Model 377A/E," Peterbilt Motors Company, Denton, Texas, Aug. 1997, 2-page brochure.

"Model 378," Peterbilt Motors Company, Denton, Texas, Mar. 1998, 3-page brochure.

"Model 379," Peterbilt Motors Company, Denton, Texas, Mar. 1996, 5-page brochure.

"Model 379," Peterbilt Motors Company, Denton, Texas, Apr. 2005, 2-page brochure.

"Model 385," Peterbilt Motors Company, Denton, Texas, Oct. 1996, 5 page brochure.

"Model 387," Peterbilt Motors Company, Denton, Texas, Oct. 2002, 2-page brochure.

"Peterbilt Parts & Accessories," Peterbilt Motors Company, Denton, Texas, catalog, as early as 2000, 52-page brochure.

"Rest with Class," Peterbilt Motors Company, Newark, California, Apr. 1978, 4-page brochure.

"Studio Sleeper," Kenworth Truck Company, Kirkland, Washington, 1993, 5-page brochure.

"T2000," Kenworth Truck Company, Kirkland, Washington, 1999, 20-page brochure.

"T2000," Kenworth Truck Company, Kirkland, Washington, 2002, 20-page brochure.

"T2000," Kenworth Truck Company, Kirkland, Washington, 2005, 20-page brochure.

"T300," Kenworth Truck Company, Kirkland, Washington, 1994, 4-page brochure.

"T300," Kenworth Truck Company, Kirkland, Washington, 1997, 5-page brochure.

"T300," Kenworth Truck Company, Kirkland, Washington, 2001, 16-page brochure.

"T300," Kenworth Truck Company, Kirkland, Washington, 2005, 16-page brochure.

"T400B and T450B," Kenworth Truck Company, Kirkland, Washington, 1992, 10-page brochure.

"T600," Kenworth Truck Company, Kirkland, Washington, 1996, 7-page brochure.

"T600," Kenworth Truck Company, Kirkland, Washington, 2002, 28-page brochure.

"T600," Kenworth Truck Company, Kirkland, Washington, 2005, 24-page brochure.

"T600, Ten Years of Innovation," Kenworth Truck Company, Kirkland, Washington, 1995, 6-page brochure.

"T600A," Kenworth Truck Company, Kirkland, Washington, 1985, 10-page brochure.

"T660," Kenworth Truck Company, Kirkland, Washington, 2007, 36-page brochure.

"T800," Kenworth Truck Company, Kirkland, Washington, 1996, 7-page brochure.

"T800," Kenworth Truck Company, Kirkland, Washington, 2002, 32-page brochure.

"T270 Class 6 and T370 Class 7," Kenworth Truck Company, Kirkland, Washington, 2008, 6-page brochure.

* cited by examiner

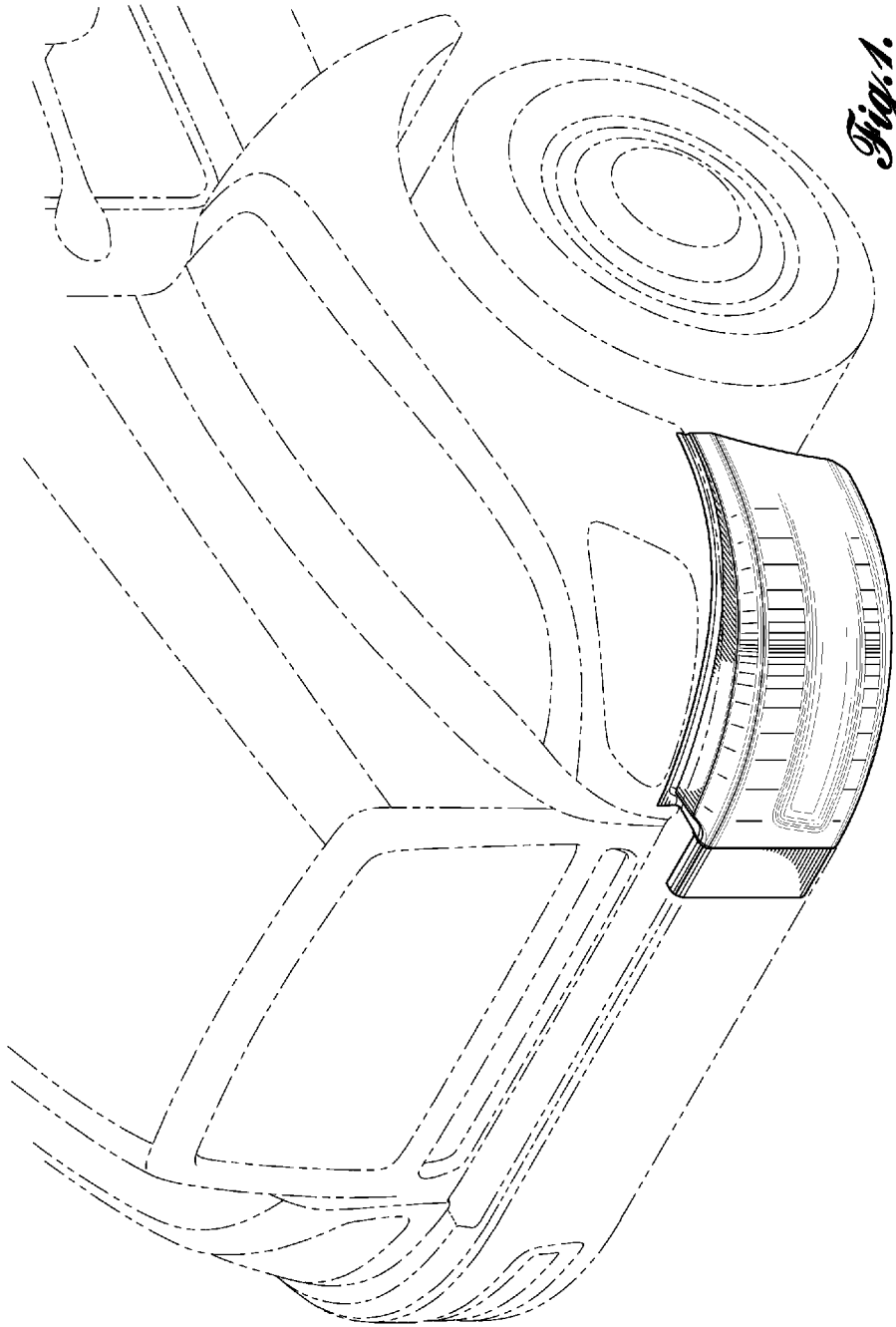

Fig. 1.

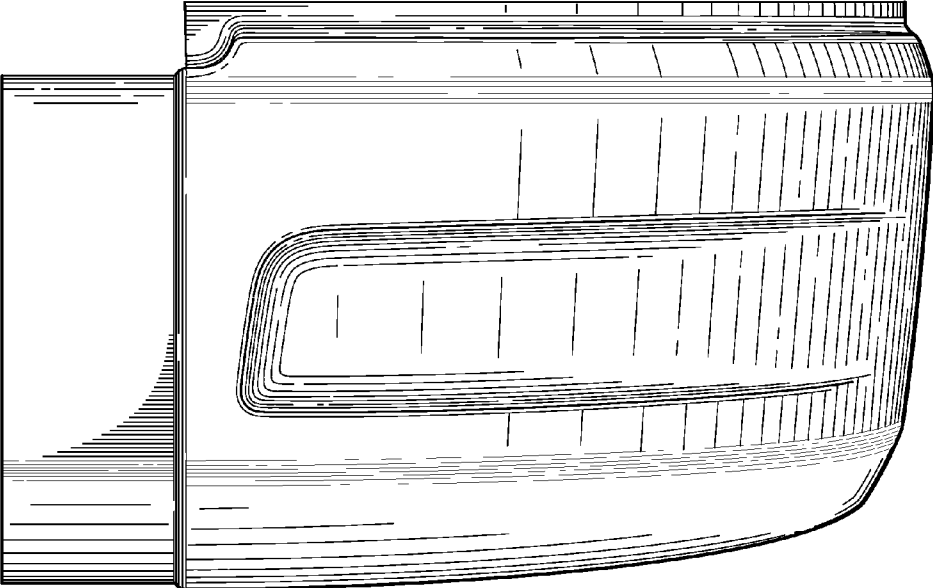

Fig. 2.

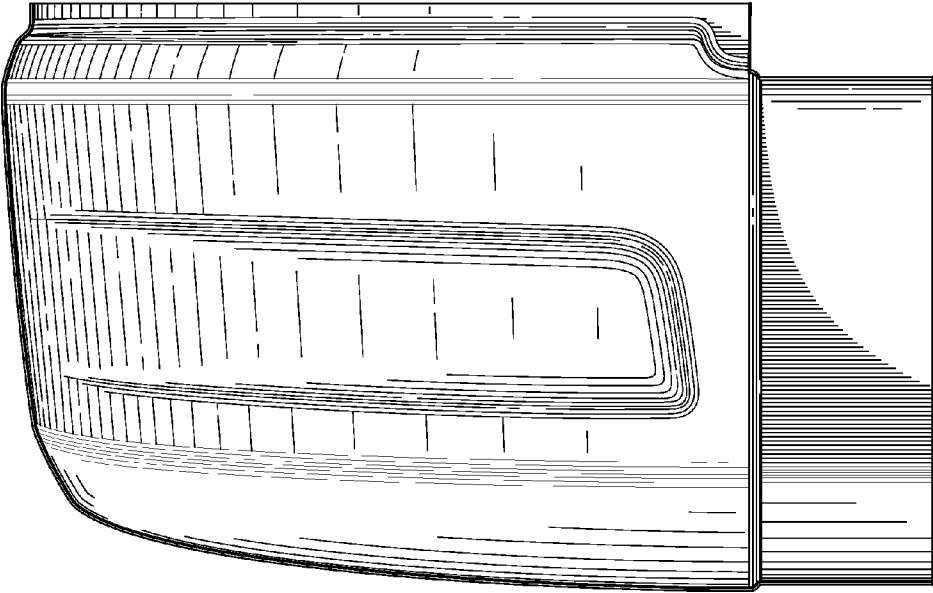

Fig. 3.

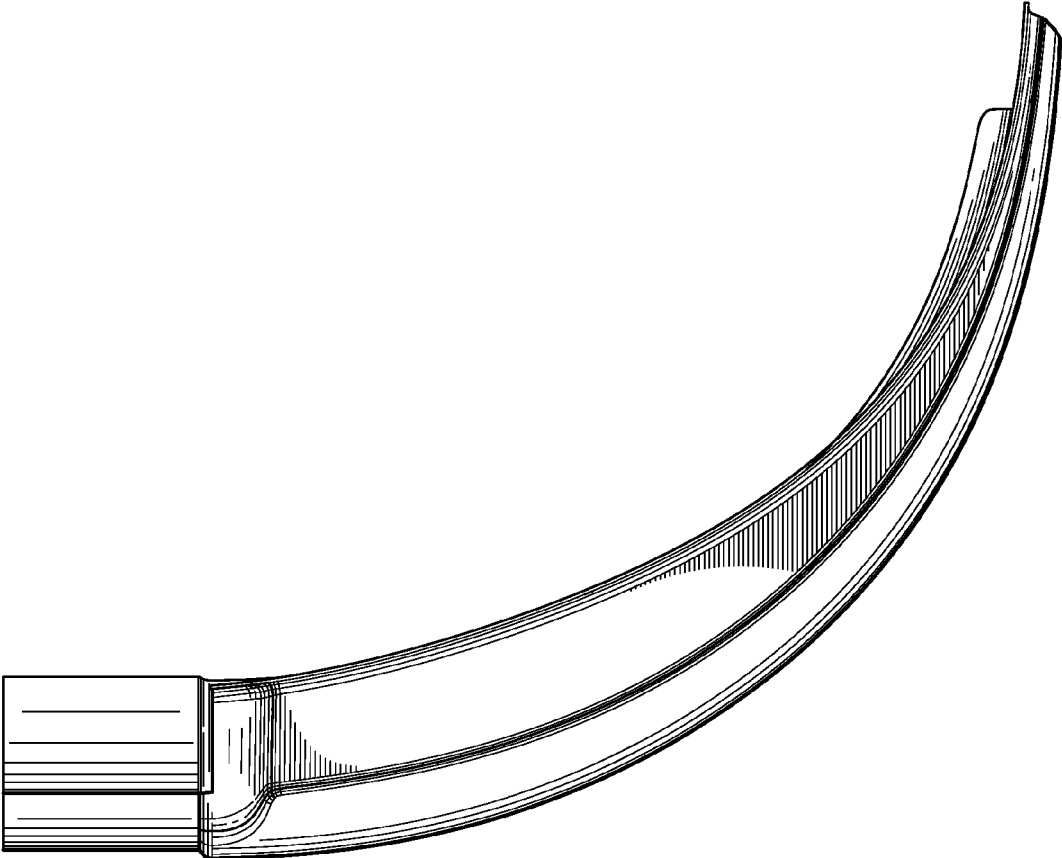

Fig. 4.

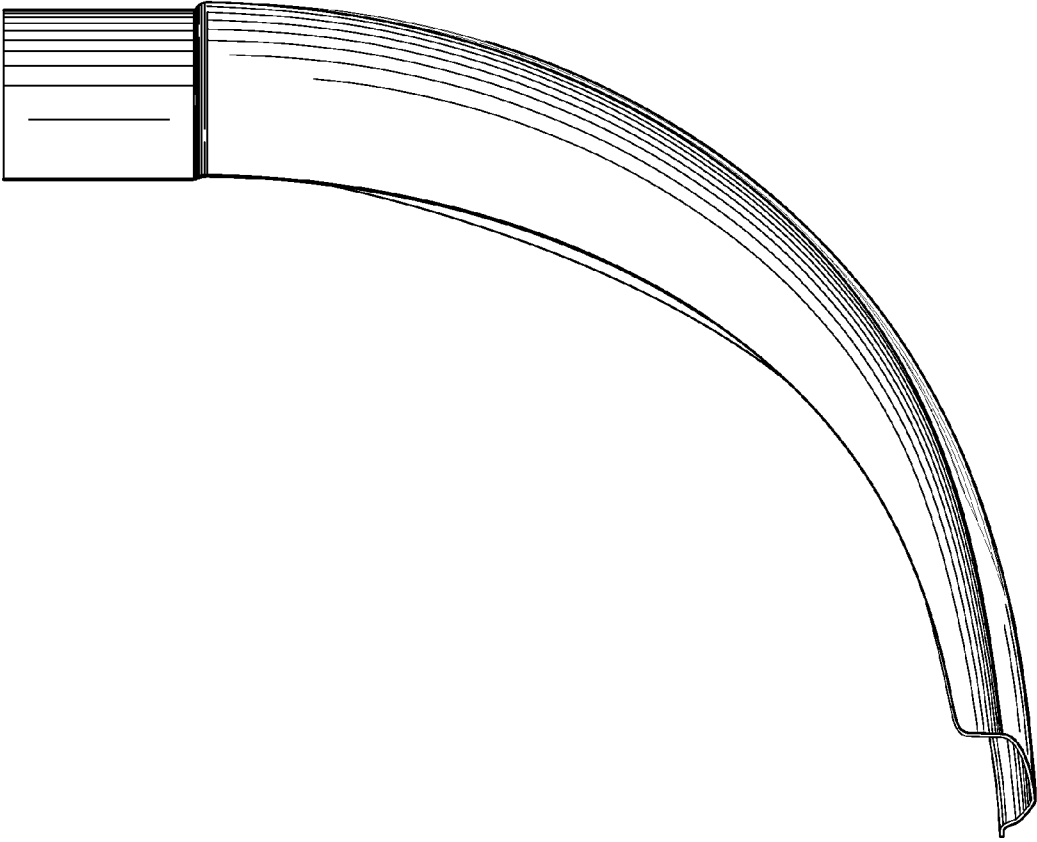

Fig. 5.

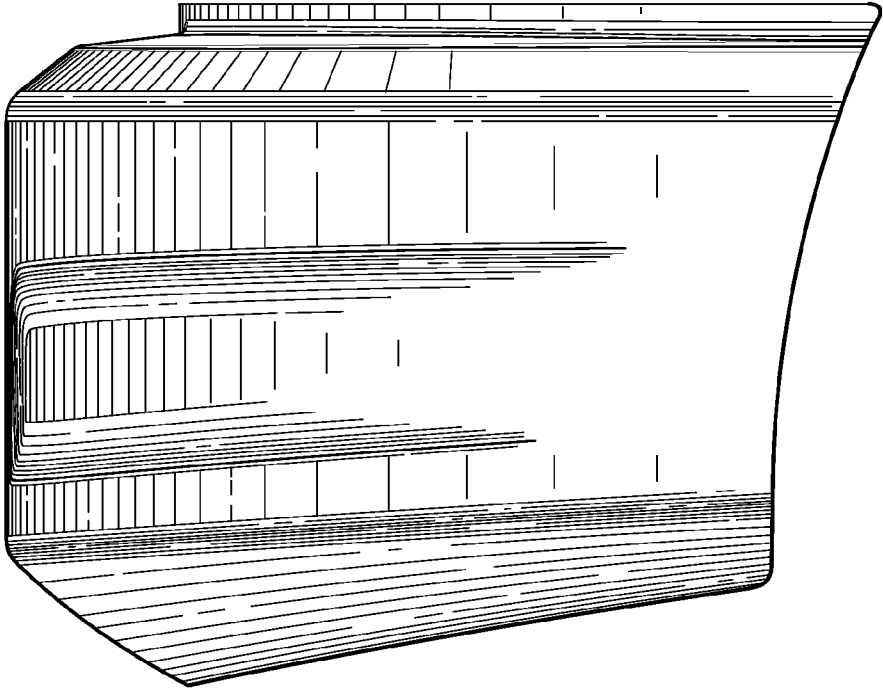

Fig. 6.

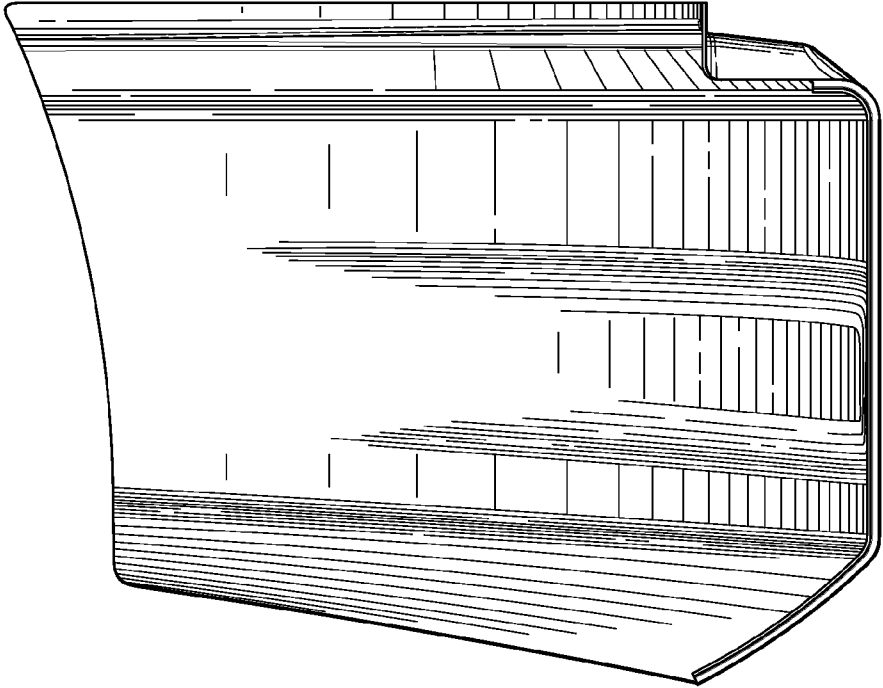

Fig. 7.