



US00D621754S

(12) **United States Design Patent**
Angelo et al.

(10) **Patent No.:** **US D621,754 S**

(45) **Date of Patent:** **** *Aug. 17, 2010**

(54) **TRUCK HOOD UNIT**

D411,140 S 6/1999 Meryman
D411,494 S 6/1999 Meryman
D412,689 S 8/1999 Onopa

(75) Inventors: **Gerald J. Angelo**, Bellevue, WA (US);
Nicholas Karol Hanculak, Woodinville,
WA (US)

(Continued)

(73) Assignee: **PACCAR Inc**, Bellevue, WA (US)

OTHER PUBLICATIONS

(**) Term: **14 Years**

"AeroCab," Kenworth Truck Company, Kirkland, Washington, 1993,
6-page brochure.

(21) Appl. No.: **29/346,950**

(Continued)

(22) Filed: **Nov. 9, 2009**

Primary Examiner—Melody N Brown

(51) **LOC (9) Cl.** **12-16**

(52) **U.S. Cl.** **D12/173**

(58) **Field of Classification Search** D12/96,
D12/97, 98, 12, 90-92; 296/180.1-180.3,
296/181.1-185, 186, 186.1; 180/89.12, 89.1,
180/242, 449

(74) *Attorney, Agent, or Firm*—Christensen O'Connor
Johnson Kindness PLLC

See application file for complete search history.

(57) **CLAIM**

The ornamental design for a truck hood unit, as shown and
described.

(56) **References Cited**

DESCRIPTION

U.S. PATENT DOCUMENTS

D248,846 S	8/1978	Stage
D268,259 S	3/1983	Lindsley
D271,864 S	12/1983	Kangas
D291,872 S	9/1987	Simons
D291,982 S	9/1987	Simons
D299,706 S	2/1989	Whitmer
D307,731 S	5/1990	Kerney
D308,032 S	5/1990	Kerney
D311,711 S	10/1990	Marlowe
D311,712 S	10/1990	Marlowe
D312,805 S	12/1990	Marlowe
D313,966 S	1/1991	Marlowe
D319,807 S	9/1991	Simons
D320,583 S	10/1991	Simons
D329,214 S	9/1992	Marlowe
D343,597 S	1/1994	Meryman
D366,638 S	1/1996	Tucker
D382,841 S	8/1997	Norwood
D395,860 S	7/1998	Meryman
D401,198 S	11/1998	Mueller
D403,636 S	1/1999	Meryman

FIG. 1 is a front perspective view of a truck hood unit showing
our new design;

FIG. 2 is a top plan view of the truck hood unit of FIG. 1;

FIG. 3 is a bottom plan view of the truck hood unit of FIG. 1;

FIG. 4 is a front elevational view of the truck hood unit of FIG.
1;

FIG. 5 is a rear elevational view of the truck hood unit of FIG.
1;

FIG. 6 is a left side elevational view of the truck hood unit of
FIG. 1; and,

FIG. 7 is a right side elevational view of the truck hood unit of
FIG. 1.

The broken line showing of vents, emblem receptacles and
light receptacles is for the purpose of illustrating portions of
the truck hood unit and forms no part of the claimed design.
The broken line showing of a bumper, tire, rear fender panel,
and a truck cab is for the purpose of illustrating environmental
structure and forms no part of the claimed design.

1 Claim, 4 Drawing Sheets

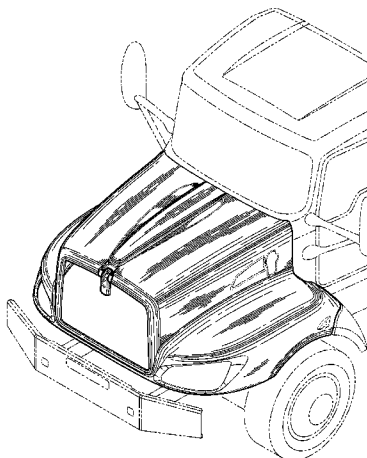

U.S. PATENT DOCUMENTS

D422,251	S	4/2000	Bader	
D423,990	S	5/2000	Meryman	
D435,816	S	1/2001	Delashaw	
D436,563	S	1/2001	Delashaw	
D437,258	S	2/2001	Meryman	
D437,570	S	2/2001	Meryman	
D446,175	S	8/2001	Hoyle, Jr.	
D450,277	S *	11/2001	Onopa	D12/173
D455,381	S	4/2002	Maher	
D460,023	S	7/2002	Beigel	
D465,749	S	11/2002	Beigel	
D466,450	S	12/2002	Maher	
D478,300	S	8/2003	Chiang	
D484,077	S *	12/2003	Conway et al.	D12/173
D488,112	S	4/2004	Satou	
D490,749	S	6/2004	Satou	
D492,921	S	7/2004	Perfetti	
D494,900	S	8/2004	Satou	
D497,581	S *	10/2004	Conway et al.	D12/173
D502,901	S *	3/2005	Delashaw et al.	D12/173
D504,642	S *	5/2005	Perfetti et al.	D12/173
D512,666	S	12/2005	Chiang	
D514,483	S	2/2006	Chiang	
D518,761	S	4/2006	Chiang	
D531,947	S	11/2006	Angelo	
D532,350	S *	11/2006	Angelo et al.	D12/173
D532,352	S	11/2006	Angelo	
D539,704	S *	4/2007	Angelo et al.	D12/96
D540,725	S *	4/2007	Gunter et al.	D12/173
D545,250	S *	6/2007	Angelo et al.	D12/173
D545,251	S *	6/2007	Angelo et al.	D12/173
D545,254	S *	6/2007	Angelo et al.	D12/184
D545,735	S	7/2007	Angelo	
D560,575	S *	1/2008	Simons et al.	D12/173
D560,582	S *	1/2008	Simons et al.	D12/196
D560,583	S	1/2008	Simons	
D561,647	S *	2/2008	Simons et al.	D12/96
D563,281	S *	3/2008	Simons et al.	D12/96
D563,849	S *	3/2008	Medina et al.	D12/173
D563,850	S *	3/2008	Rosen et al.	D12/173
D563,851	S *	3/2008	Rosen et al.	D12/173
D563,852	S *	3/2008	Rosen et al.	D12/173
D571,696	S *	6/2008	Rosen et al.	D12/173
D578,453	S	10/2008	Raghavendran	
D588,512	S *	3/2009	Raghavendran et al.	D12/173

OTHER PUBLICATIONS

“AeroCab,” Kenworth Truck Company, Kirkland, Washington, as early as 1995, 3-page brochure.
 “C500B,” Kenworth Truck Company, Kirkland, Washington, as early as 1990, 4-page brochure.
 “Cabovers,” Peterbilt Motors Company, Newark, California, as early as 2000, 7 page brochure.
 “Class Pays,” Peterbilt Motors Company, Denton, Texas, Sep. 1997, 10-page brochure.
 “Class Pays,” Peterbilt Motors Company, Denton, Texas, Nov. 1998, 10 page brochure.
 “Class Pays, Construction Trucks,” Peterbilt Motors Company, Denton, Texas, Nov. 2003, 16-page brochure.
 “Class Pays, Ergonomic Dash,” Peterbilt Motors Company, Denton, Texas, Mar. 2000, 2 page brochure.
 “Class Pays, Medium Duty,” Peterbilt Motors Company, Denton, Texas, Sep. 2000, 12-page brochure.
 “Class Pays, Platinum Interior,” Peterbilt Motors Company, Denton, Texas, May 2005, 4 page brochure.
 “Class Pays, Refuse Trucks,” Peterbilt Motors Company, Denton, Texas, Sep. 2003, 2 page brochure.
 “Class Pays, Truck Models,” Peterbilt Motors Company, Denton, Texas, Mar. 2005, 24-page brochure.

“Construction Trucks,” Canadian Kenworth Truck, Mississauga, Ontario, Canada, Jul. 1990, 16-page brochure.
 “Interiors,” Kenworth Truck Company, Kirkland, Washington, 2005, 16-page brochure.
 “K100E,” Kenworth Truck Company, Kirkland, Washington, 1984, 8-page brochure.
 “Model 320,” Peterbilt Motors Company, Denton, Texas, May 1996, 2 page brochure.
 “Model 330,” Peterbilt Motors Company, Denton, Texas, Oct. 1997, 3 page brochure.
 “Model 357,” Peterbilt Motors Company, Denton, Texas, May 1994, 3-page brochure.
 “Model 357 Heavy Haul,” Peterbilt Motors Company, Denton, Texas, Mar. 2005, 2 page brochure.
 “Model 357, New Sloped Hood,” Peterbilt Motors Company, Denton, Texas, May 2002, 2 page brochure.
 “Model 357 Standard Specifications,” Peterbilt Motors Company, Newark, California, Sep. 1986, 6 page brochure.
 “Model 357-115,” Peterbilt Motors Company, Denton, Texas, Mar. 2005, 2 page brochure.
 “Model 362,” Peterbilt Motors Company, Newark, California, 1985, 8-page brochure.
 “Model 375 Standard Specifications,” Peterbilt Motors Company, Newark, California, Sep. 1986, 6 page brochure.
 “Model 377A/E,” Peterbilt Motors Company, Denton, Texas, Jan. 1995, 6-page brochure.
 “Model 377A/E,” Peterbilt Motors Company, Denton, Texas, Aug. 1997, 2-p. brochure.
 “Model 378,” Peterbilt Motors Company, Denton, Texas, Mar. 1998, 3-page brochure.
 “Model 379,” Peterbilt Motors Company, Denton, Texas, Mar. 1996, 5-page brochure.
 “Model 379,” Peterbilt Motors Company, Denton, Texas, Apr. 2005, 2-page brochure.
 “Model 385,” Peterbilt Motors Company, Denton, Texas, Oct. 1996, 5 page brochure.
 “Model 387,” Peterbilt Motors Company, Denton, Texas, Oct. 2002, 2-page brochure.
 “Peterbilt Parts & Accessories,” Peterbilt Motors Company, Denton, Texas, catalog, as early as 2000, 52-page brochure.
 “Rest with Class,” Peterbilt Motors Company, Newark, California, Apr. 1978, 4-page brochure.
 “Studio Sleeper,” Kenworth Truck Company, Kirkland, Washington, 1993, 5-page brochure.
 “T2000,” Kenworth Truck Company, Kirkland, Washington, 1999, 20-page brochure.
 “T2000,” Kenworth Truck Company, Kirkland, Washington, 2002, 20-page brochure.
 “T2000,” Kenworth Truck Company, Kirkland, Washington, 2005, 20-page brochure.
 “T300,” Kenworth Truck Company, Kirkland, Washington, 1994, 4-page brochure.
 “T300,” Kenworth Truck Company, Kirkland, Washington, 1997, 5-page brochure.
 “T300,” Kenworth Truck Company, Kirkland, Washington, 2001, 16-page brochure.
 “T300,” Kenworth Truck Company, Kirkland, Washington, 2005, 16-page brochure.
 “T400B and T450B,” Kenworth Truck Company, Kirkland, Washington, 1992, 10-page brochure.
 “T600,” Kenworth Truck Company, Kirkland, Washington, 1996, 7-page brochure.
 “T600,” Kenworth Truck Company, Kirkland, Washington, 2002, 28-page brochure.
 “T600,” Kenworth Truck Company, Kirkland, Washington, 2005, 24-page brochure.
 “T600, Ten Years of Innovation,” Kenworth Truck Company, Kirkland, Washington, 1995, 6-page brochure.
 “T600A,” Kenworth Truck Company, Kirkland, Washington, 1985, 10-page brochure.
 “T660,” Kenworth Truck Company, Kirkland, Washington, 2007, 36-page brochure.

US D621,754 S

Page 3

"T800," Kenworth Truck Company, Kirkland, Washington, 1996, 7-page brochure.

"T800," Kenworth Truck Company, Kirkland, Washington, 2002, 32-page brochure.

"T800," Kenworth Truck Company, Kirkland, Washington, 2003, 32-page brochure.

"T800," Kenworth Truck Company, Kirkland, Washington, 2005, 28-page brochure.

"T8006," Kenworth Truck Company, Kirkland, Washington, 1993, 8-page brochure.

"The Working Class," Peterbilt Motors Company, Newark, California, Sep. 1976, 6 page brochure.

"The World's Best," Kenworth Truck Company, Kirkland, Washington, 1992, 12-page brochure.

"Unibilt™ Cab Sleeper System," Peterbilt Motors Company, Denton Texas, Aug. 1994, 6 page brochure.

"W900," Kenworth Truck Company, Kirkland, Washington, 1996, 7-page brochure.

"W900," Kenworth Truck Company, Kirkland, Washington, 2002, 32-page brochure.

"W900," Kenworth Truck Company, Kirkland, Washington, 2005, 28-page brochure.

"W900L Aero Cab," Kenworth Truck Company, Kirkland, Washington, 1994, 2-page brochure.

"T270 Class 6 and T370 Class 7," Kenworth Truck Company, Kirkland, Washington, 2008, 6-page brochure.

* cited by examiner

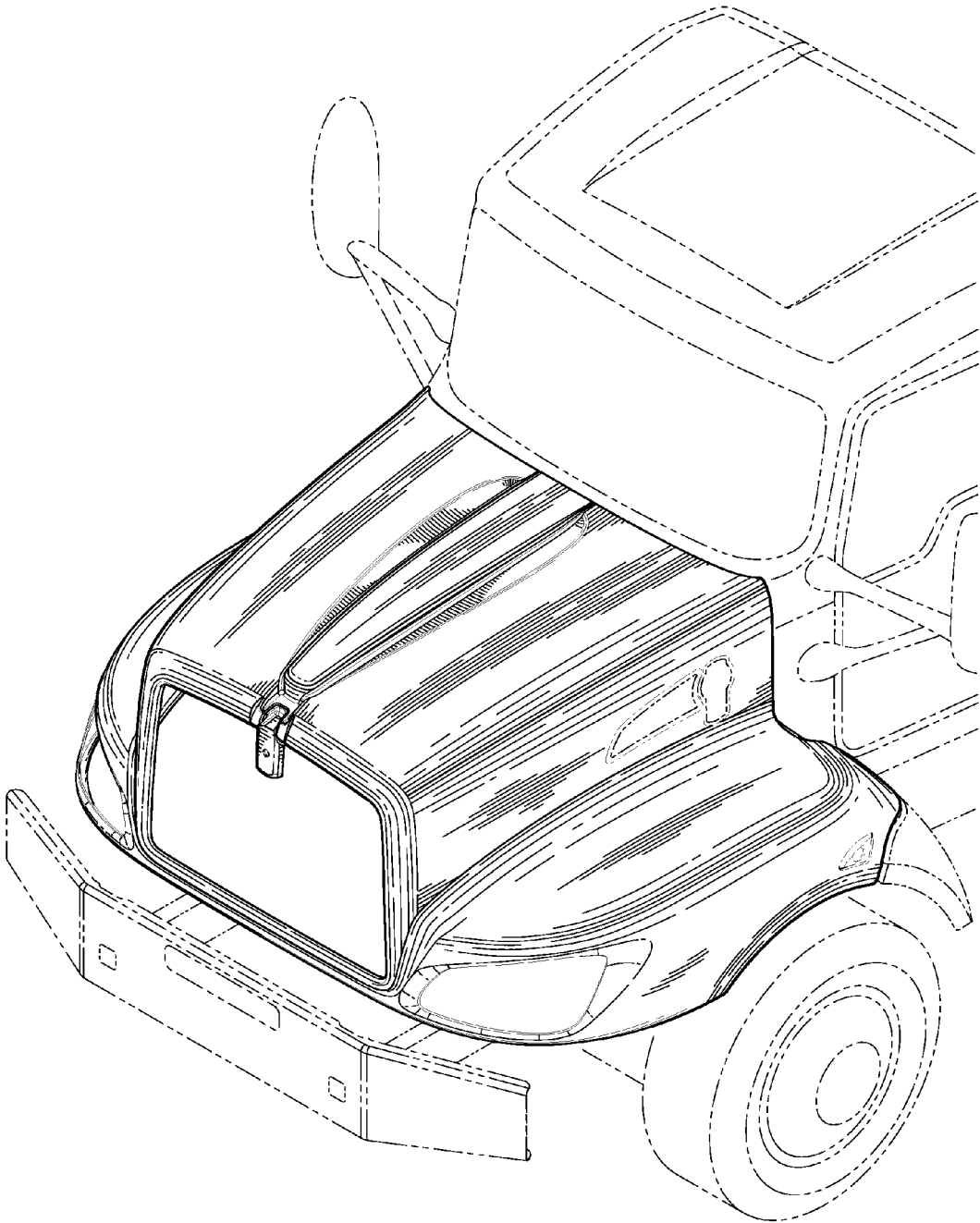

Fig. 1.

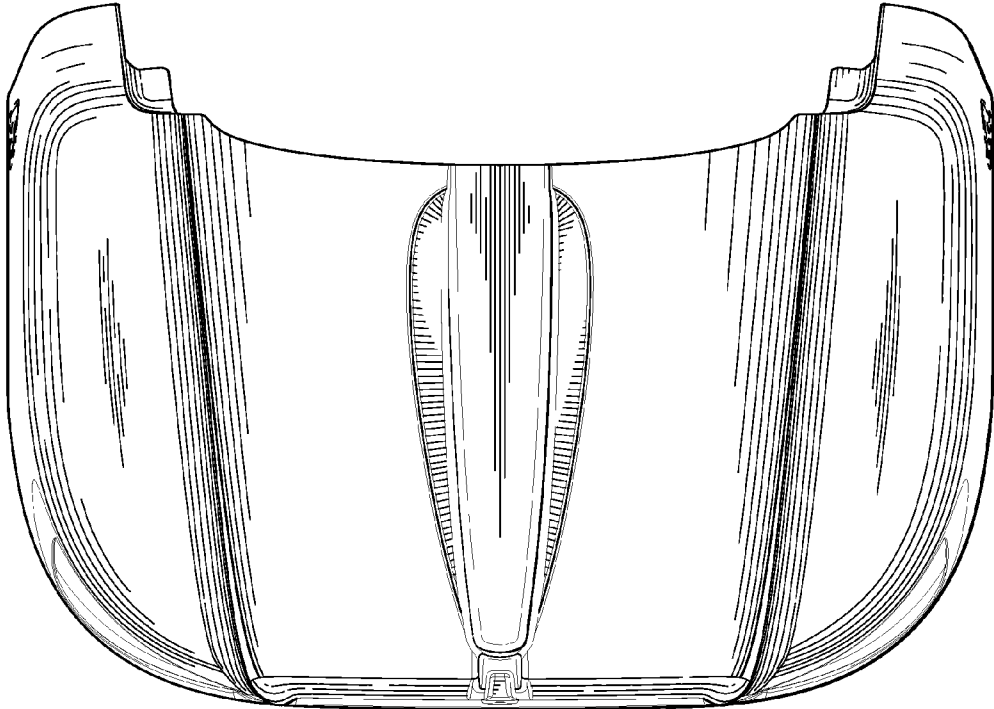

Fig. 2.

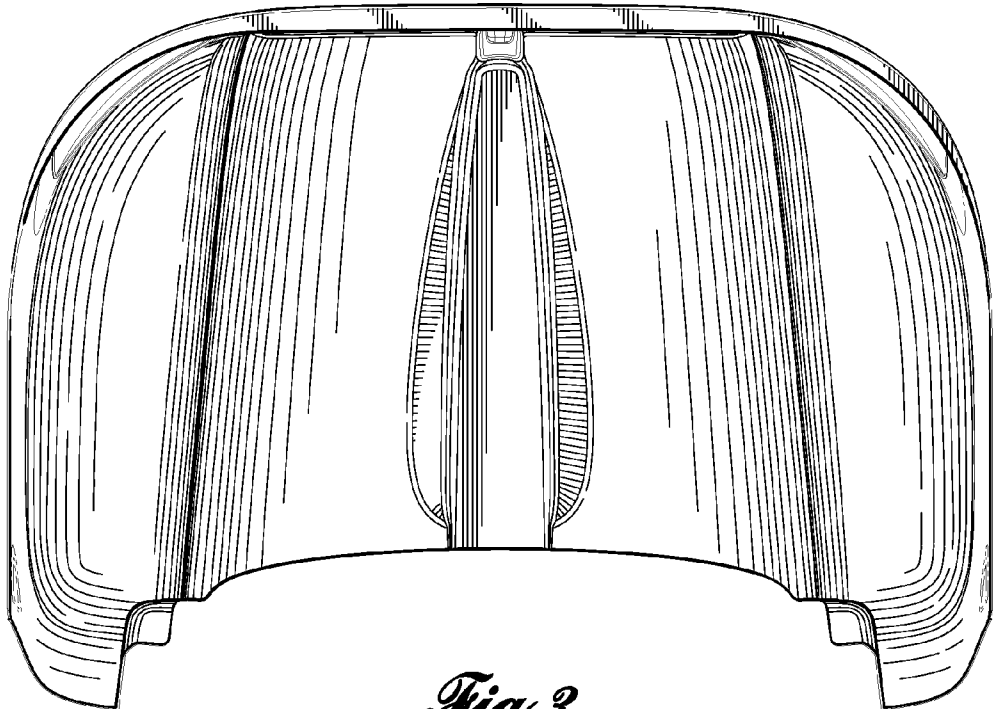

Fig. 3.

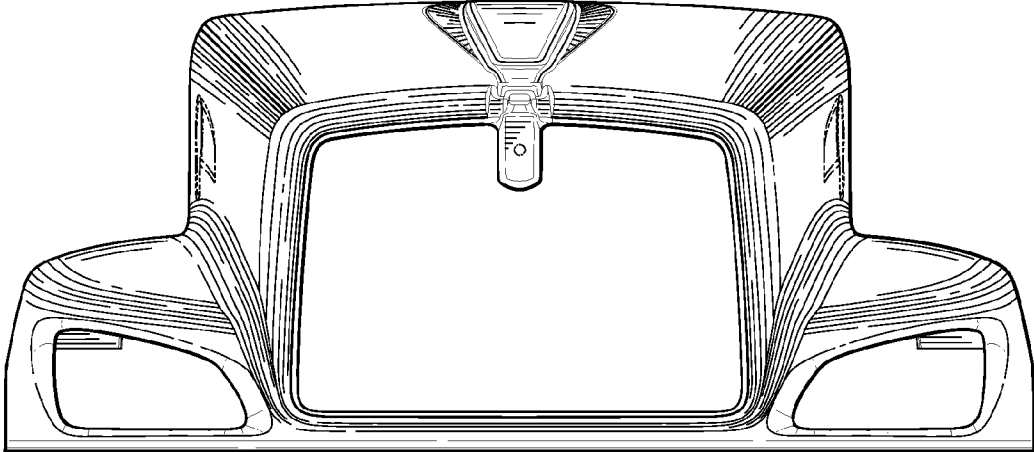

Fig. 4.

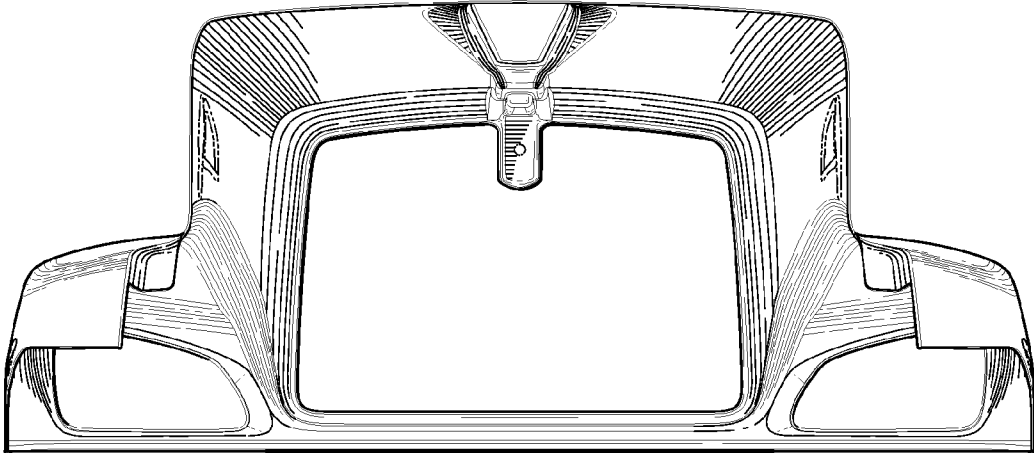

Fig. 5.

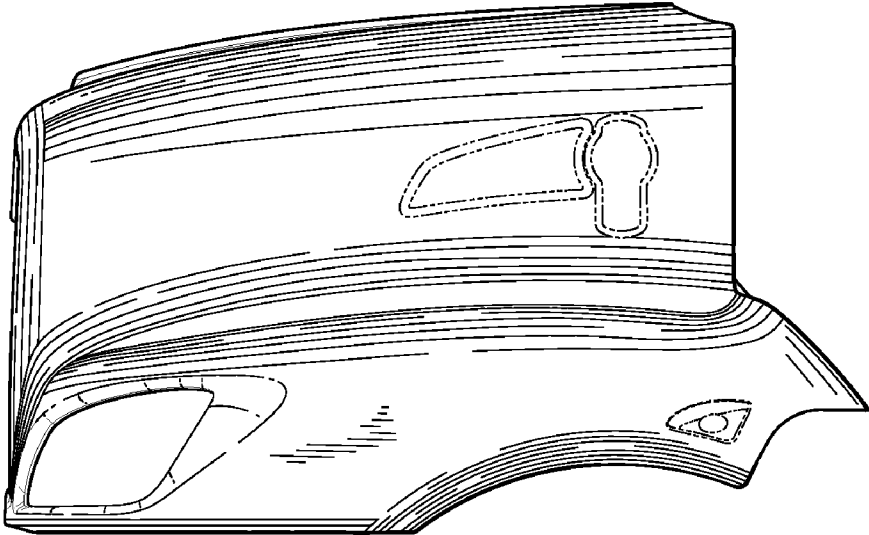

Fig. 6.

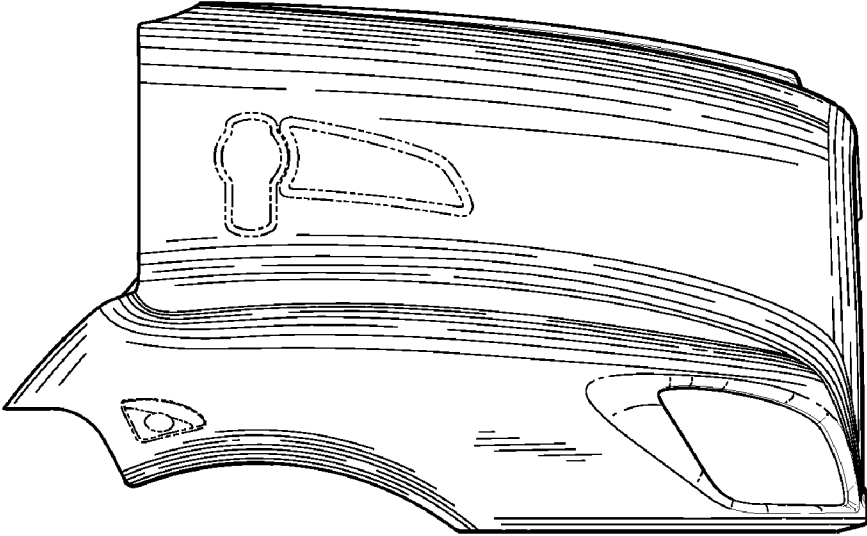

Fig. 7.